



Schwiebacher Abbruch Technik

Werkstatt • Lager • Service seit 1977

D-82229 Seefeld (bei München)

Graf-Toerring-Seefeld-Strasse 9b / 17

Tel. 08152 / 998 969-0 Fax.- 9

T.48/T.50 GRABENRÄUM-LÖFFEL (Holland-Profil) optimal* für Bagger von 7,1 bis 12,5 to

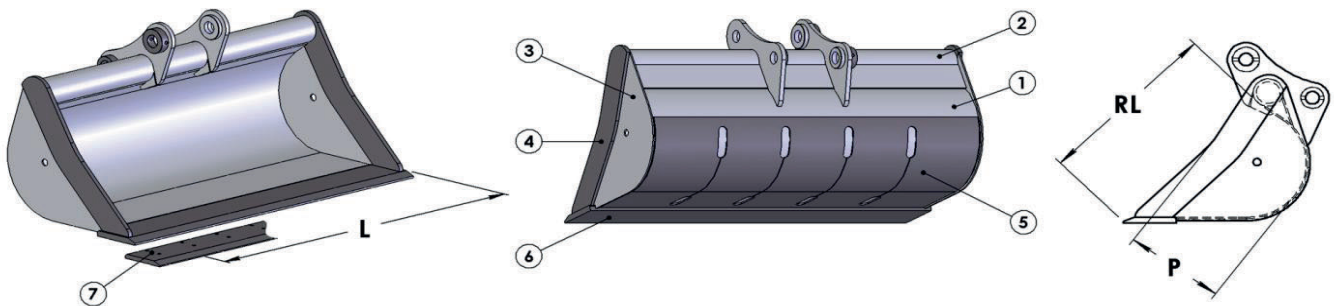
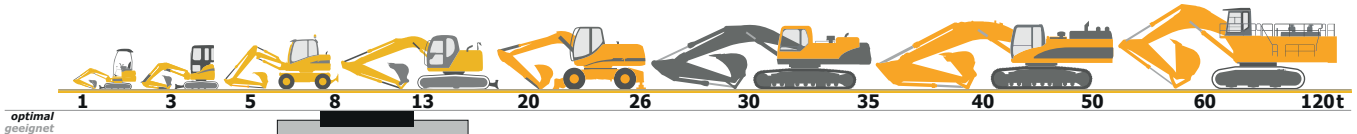

Klasse Class Classe	Bestell Nr. Code Code	L mm.	Cap. SAE Lt.	Gewicht kg Weight Poids	RL mm.	P mm.	Preis € Price List Tarif	Unterschraubmesser Bolt on Blade Lame boulonnées
T.48 T.50 7,1-12,5 ton	T48PFO140	1400	348	244	649	358		
	T48PFO150	1500	375	258				
	T48PFO160	1600	403	271				
	T48PFO180	1800	458	298				
	T48PFO200	2000	513	324				
		1	2	3	4	5	6	7 Optional
Material	Material Matériel	Fe 510	Fe 510	Fe 510	Hardox	Fe 510	Hb 400	Hb 400
Stärke	Thickness Espessure	6 mm	114.3 x 12.5 mm	8 mm	15 mm	6 mm	200 x 20 mm	200 x 20 mm

*optimal = für Bagger von 7,1 bis 12,5 t mit Standard-Ausrüstung.

T.48 Atlas 1004/1102D; Benati 3.06/3.07R/3.08R/5.08/5.10; BobCAT 442; Case 488/9007/WX 90/WX 95/CX 75/CX 75SR/CX 80; Caterpillar E 307/E 70/E 70B/307C/308C CR; Daewoo Doosan 070-III/075-V; Eurocomach ES-800; Euromach 8500/TIGRONE; Fai 409/410C/W/750 C/900CH/GTH/GTV; Fiat Hitachi EX 60/EX 60.5/E X 60WD/FH 65W/EX 75U R/EX 75US/FH 85W/FH 9 0WT/FH 95; Fiat Kobelco E 70SR/E 80 SR; Hanix H 75B; Hitachi ZX 70/ZX 80SB/ZX 85US; Hydrema R 800; Hyundai R 95W-3; Ihi-Imer 80 NX/80NX3; JCB JS 70/JZ 70/8080ZTS; Kamo MOBIL 70; Kobelco SK 75UR/SK 80 MSR/YUTANI SK 03; Komatsu PC 75/75R/PC 75R2/PC 75UU/PC 75UU/PC 78MR6/PC 95R/PC 95R2/PW 75/PW 95/PC 58U; Kubota KX 251; Kramer 806/808; Liebherr A 307/A 308/R 308; Macmoter M 7/M 8/M 8M/M 10/BW 75/BW 95; Mecalac 11CX/12CX/12MX/12MSX; Neuson 7002RD/8002RD/75Z3; New Holland E 80MS R; O&K 2.8C/2.8D/MH 2.5; Schaeff HR 41/HML 40/HML 41/HML 42/HS 40A/B/D/HS 41/SKB 1000; Takeuchi TB 80FR/TB 175/TB 175W; Terex 960/970; Venieri VF 12.23; Volvo E CR 88; Yanmar Vio 75/Vio 100.

T.50 Akermann H 3B; Atlas 1104/1204; Benati 3.12R; Benfra 3R/3C; BobCAT 444; Case WX 120; Cosmoter BAT 10; Euromach 9000/9500; Fiat Hitachi FH 115W/FH 120W/EX 100/FH 115; Fiat Kobelco E 115SR/EX 125W; Hitachi ZX 110; Hyundai R110LC7; JCB JS 110; Kobelco SK 100/SK 115SR; Komatsu PC 110R/PC 110R1/PW 110R/PC 120; Laltesi 40/111; Liebherr A 309/A 310/A 311; Macmoter M 12M/BW 110; Mecalac 14M X/14MBX; MF 250; Neuson 1002RD/12002RD; New Holland MH 2.6/MH 3.6/E 115SR; O&K MH 2.10/MH 3.5; PMI 450/810R/913; Terex HR 42.

geeignet = für Bagger von 6,0 bis 16 t je nach Ausrüstung. Andere Klassen/Größen bedingt geeignet. Bei Bedarf bitte anfragen!