



Schwiebacher Abbruch Technik

Werkstatt • Lager • Service seit 1977

D-82229 Seefeld (bei München)

Graf-Toerring-Seefeld-Strasse 9b / 17

Tel. 08152 / 998 969-0 Fax.- 9

T.60 LADE-SCHWENK-LÖFFEL *optimal**

(2 Zylinder stehend, Holland-Profil) für Bagger von 16 bis 19 to

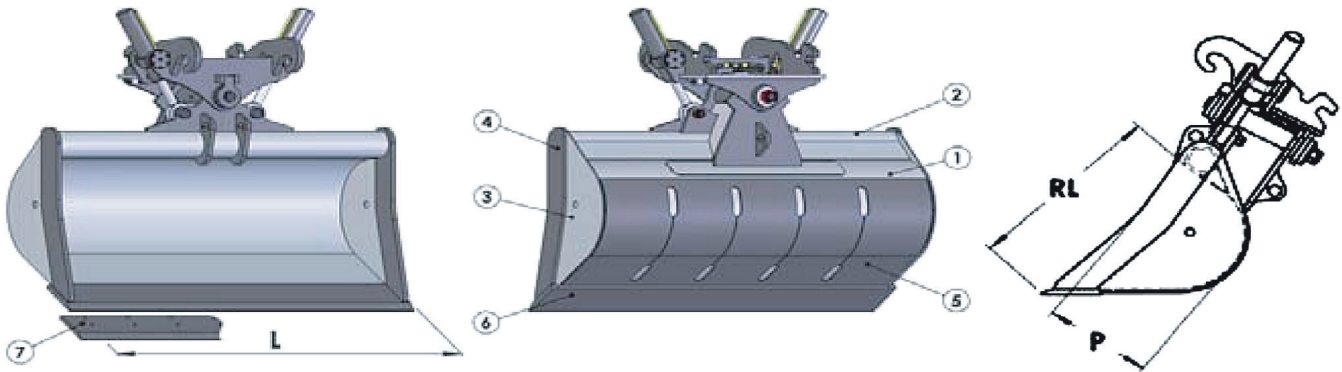
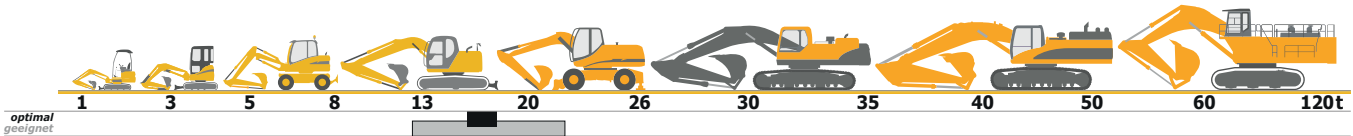

Klasse Class Classe	Bestell Nr. Code Code	L mm.	Cap. SAE Lt.	Anz. Zylinder Cylinders Vérins	Gewicht kg Weight Poids	RL mm.	P mm.	Preis Price List Tarif	Unterschraubmesser Bolt on Blade Lame boulonnées
T.60 16-19 ton	T60ORO150	1500	677	2	753	900	473		
	T60ORO160	1600	730	2	775				
	T60ORO180	1800	832	2	820				
	T60ORO200	2000	935	2	862				
	T60ORO220	2200	1038	2	905				
		1	2	3	4	5	6	/	7 Optional
Material	<i>Material Matériel</i>	Fe 510	Fe 510	Fe 510	Hardox	Fe 510	Hb 400	/	Hb 400
Materialstärke	<i>Thickness E spessore</i>	8 mm	127 x 14.2 mm	8 mm	20 mm	8 mm	250 x 25 mm	/	250 x 25 mm

*optimal = für Bagger von 16 bis 19 t mit Standard-Ausrüstung.

Akermann H 7B/H 7C; **Atlas** 1604M/1604LC/1622; **Benati** 160/3.18; **Benfra** 6C/7R/7.07/7.08/9.07/9.08/9.20;
Case 688/688B/788/CX 160/WX 150/WX 165/WX 170/CX 180; **Caterpillar** 211/212/213B/214/214B/315/317/318/M 316C/
M 318C/315C; **Cosmoter** BAT 16; **Daewoo Doosan** DH 170/DH 180/S 170III/V/S 175LCV/S 180WV; **FAI** 1100;
Fiat Hitachi FH 150.3/EX 165/FH 150 W.2/FH 150W.3; **Fiat Kobelco** E 165 LC/E 175W; **Fiat-Allis** FE 18; Ford 44/45;
Furukawa 635E; **Hitachi** ZX 160LC/ZX 180LC/ZX 160W/ZX180W; **Hydromac** H 85; **Hyundai** R 160LC-3/7/R 170W-3/R 180LC-3/7;
JCB JS 150/JS 160LC/JS 160W/JS 175W/JS 180LC; **Kobelco** SK 150/SK 160LC/904/905B/SK 170LC;
Komatsu PC 160-7/PW 160-7/PW 170/PC 180-7/PW 1 80-7; **Laltes** 80/341/341HD;
Liebherr A 9 00C/A 900B LIT/A 902 LIT/A 314 LIT/A 316 LIT/R 317; **MF** 350D/350E;
New Holland E 175/MH PL US/MH PLUS C/MH 5.6;
O&K RH 5/RH 5PLUS/RH 5 PMS/MH 5/MH 5PMS/RH 5.5; **PMI** 900/8.18; **Poclair** 61/75/688; ROCK 100;
Samsung SE 170W.3; **Volvo** EC 160B/EC 170/EW 170/EC 180B/EW 180B.

geeignet = für Bagger von 12,5 bis 22 t je nach Ausrüstung.
Andere Klassen/Größen bedingt geeignet. Bei Bedarf bitte anfragen!